



**STRONG PARTNERS.
TOUGH TRUCKS.™**



HYSTER UT SERIES

ELECTRIC WALKIE STACKER

S1.5UT / 1500KG

HYSTER.COM.AU

> OVERVIEW

\$1.5UT

THE HYSTER® WALKIE STACKER \$1.5UT GIVES THE USER SUBSTANTIAL PRODUCTIVITY CAPABILITIES WITH THE OPERATIONAL COST OF A WALKIE RATHER THAN A RIDER. THE VERSATILITY OF SELECTABLE PERFORMANCE MODES AS WELL AS USEFUL FEATURES HELPS TO INCREASE USER PRODUCTIVITY.

Productivity

- Maintenance free AC motor
- Multi-function display with BDI and hour meter
- Emergency reversing button
- Auto deceleration function
- Low speed switch
- Variable speed control
- Sideways battery removal with rollers
- Mast cushioning for low-noise operation
- Built-in pressure relief valve protects from overloads
- Emergency power disconnect switch
- Cold store configuration (option)

Optimum Structural Design

- Low centre of gravity enhances stability
- Full free lift mast options for low overhead clearance
- Durable plastic covers
- Adjustable balance casters improve stability

Serviceability

- Low voltage protection setting extends the battery life
- CANbus technology
- Simple electronic components makes troubleshooting and servicing more efficient
- Hall effect sensors reduce wear and increase component life



**Handle (Standard)
(Left & Right Handed)**



Fork Lengths to Suit All Applications



One Sided (Cold Store)



Two Sided (Cold Store)

LOAD CHARTS

Load Centre Chart

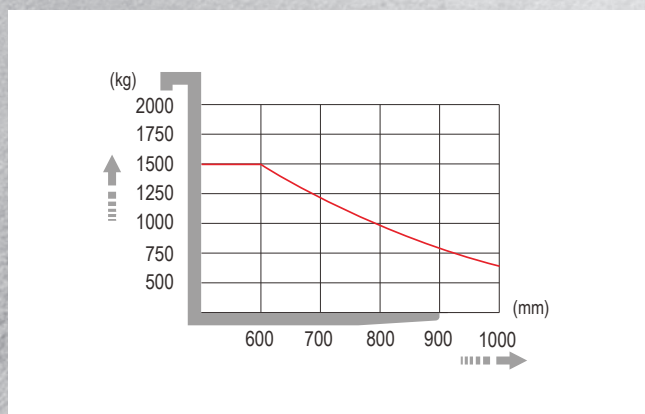

Load Capacity Chart

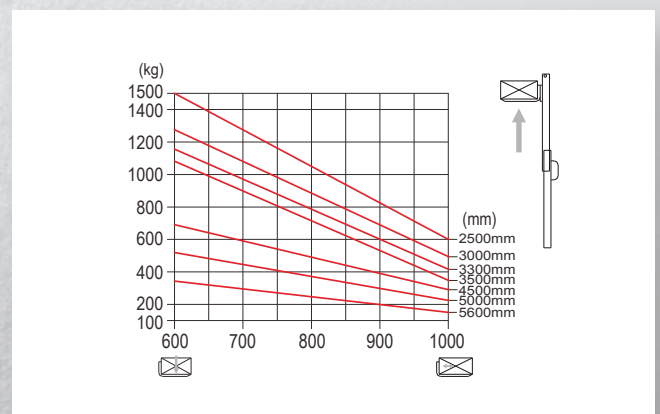

SPECIFICATIONS AND DIMENSIONS <

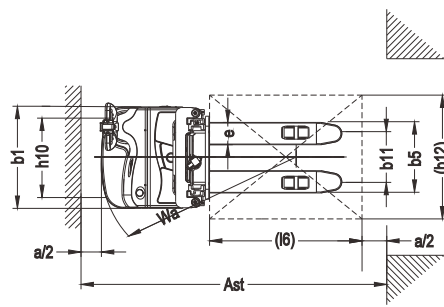
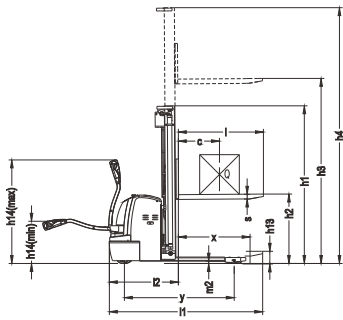

MODEL	MEASUREMENT	S1.5UT						
Load capacity	Q (kg)	1500						
Load centre distance	c (mm)	600						
Load distance, centre of drive axle to fork	x (mm)	697						
Wheelbase	y (mm)	1410						
Fork height, lowered	h13 (mm)	90						
Tyre size, front	mm	Φ250x70						
Tyre size, rear	mm	Φ80x84						
Additional wheels (dimensions)	mm	Φ150x60						
Wheels, number front rear (x=driven wheels)		1x+1/4						
Height, mast lowered	h1 (mm)	1735	1985	2135	2235	2050	2210	2410
Free lift (option 2500-3500mm)	h2 (mm)	0	0	0	0	1570	1740	1940
Max. lift height	h3 (mm)	2500	3000	3300	3500	4500	5000	5600
Height, mast extended	h4 (mm)	2955	3455	3755	3955	5030	5510	6110
Height of tiller in drive position min./max.	h14 (mm)	670/1300						
Overall length	l1 (mm)	1950						
Length to face of forks	l2 (mm)	878						
Overall width	b1 (mm)	820						
Fork dimensions	s/e/l (mm)	60/180/1070 (1150)						
Width overall forks	b5 (mm)	570/695						
Aisle width for pallets 800x1200 lengthways	Ast (mm)	2420						
Turning radius	Wa (mm)	1575						
Drive motor power	kW	1.2						
Lift motor power	kW	3.0						
Sound level at the driver's ear according to DIN12503	dB (A)	70						
Travel speed, laden/unladen	Km/h	5.8/6						
Lift speed, laden/unladen	m/s	0.11/0.15						
Lowering speed, laden/unladen	m/s	0.12/0.12						
Battery voltage, nominal capacity K (Duplex Mast)	V/Ah	24/240						
Battery voltage, nominal capacity K (Triplex Mast)	V/Ah	24/240						
Battery weight	kg	220						
Battery dimensions l/w/h	mm	625x254x500						
Service weight (with battery)	kg	1140/1190/1200/1290/1370/1400/1530						

S1.5UT Power Plug Type





HYSTER® DEALERS

Contact your nearest Hyster® Dealership
by visiting www.hyster.com.au

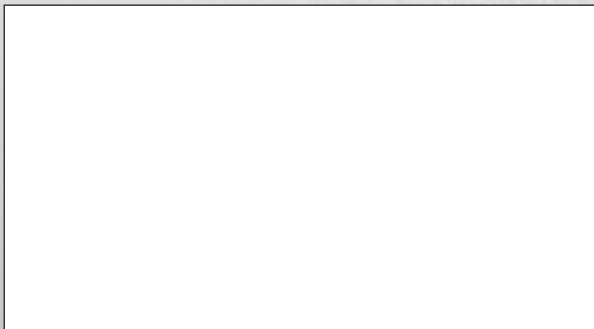

HYSTER PACIFIC

1 Bullecourt Avenue, Milperra NSW, Australia 2214
Tel: +61 (2) 9795 38007 Fax: +61 (2) 9792 8484
hyster.com/pacific/en-au

HYSTER ASIA

16 Tuas Avenue 20, Singapore 638827
Tel: +65 6863 3387 Fax: +65 6863 3349
hyster.com/asia/en-sg



/Hysterasiapacific



HysterJAPIC



Hyster Asia-Pacific