



**STRONG PARTNERS.  
TOUGH TRUCKS.™**



# **HYSTER UT SERIES**

## **ELECTRIC WALKIE PALLET TRUCK**

**P2.0UTE / 2000KG**

**[HYSTER.COM.AU](http://HYSTER.COM.AU)**

## > OVERVIEW

# P2.UTE

**THE HYSTER® ELECTRIC WALKIE PALLET TRUCK P2.UTE COMBINES ERGONOMIC FEATURES AND RELIABLE PERFORMANCE WITH ENERGY EFFICIENT TECHNOLOGY. THE LOW-MAINTENANCE HELPS INCREASE PRODUCTIVITY AND REDUCE OPERATIONAL COSTS.**

### Standard Features

- Brushless maintenance free AC motor
- Sealed maintenance free batteries
- Small turning radius 1335mm-1405mm (width 520/550/685mm)
- Self-adjusting caster wheels
- Drive capability when tiller is upright, greatly reducing turning space
- Tiller head with max. speed limit button
- Emergency stop and belly button
- Casters to increase stability
- Exit roller
- BDI and hour meter
- Built-in charger

### Options

- External charger
- Various fork widths and lengths available



**Handle (Standard)  
(Left & Right Handed)**



**Entry Roller for  
Easy Operation**

## TURNING RADIUS

**The P2.UTE has a small turning radius. When switched to low speed it adapts to narrow spaces. Ideal for shipping containers and tail gate applications.**

### MINI Type Pallet Truck

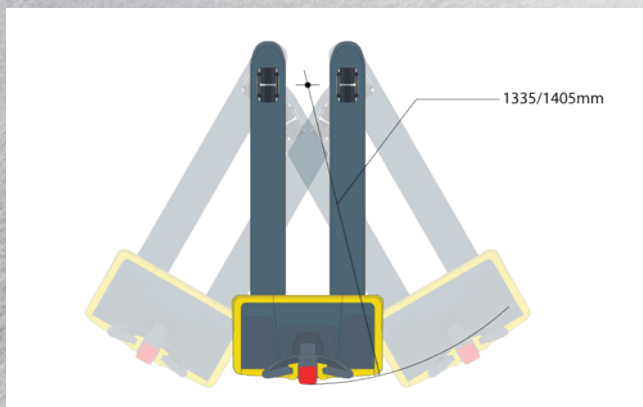

### Hand Pallet Truck

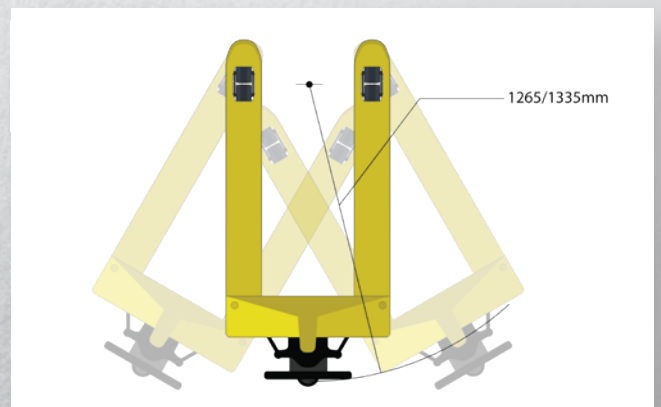

# SPECIFICATIONS AND DIMENSIONS

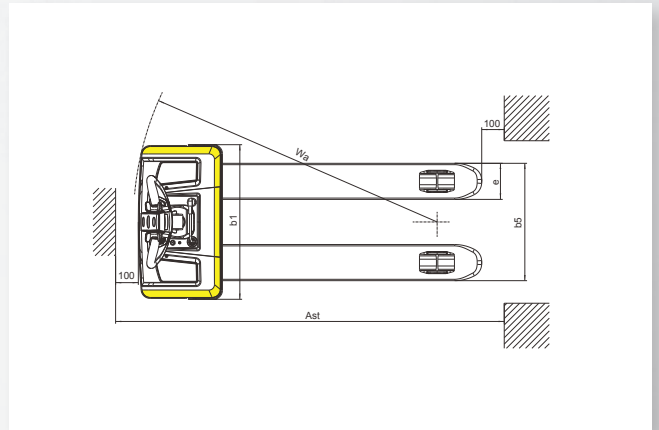
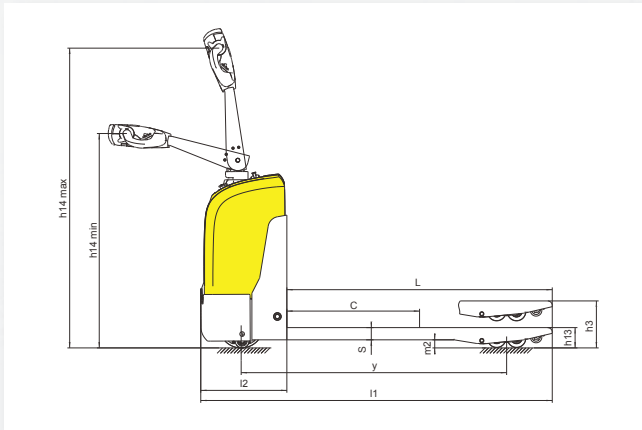

MODEL	MEASUREMENT	P2.0UTE
Load capacity	Q (kg)	2000
Load centre distance	c (mm)	600
Wheelbase	y (mm)	1130
Fork height, lowered	h13 (mm)	85/75
Tyre size, front	mm	Φ195x70
Tyre size, rear (single)	mm	Φ80x93/Φ74x93
Tyre size, rear (double)	mm	Φ80x70/Φ74x70
Wheels number front rear (x = driven wheels)		1X-2/4
Max. lift height	h3 (mm)	190/180
Height of tiller in drive position min./max.	h14 (mm)	950/1310
Overall length	l1 (mm)	1525/1595
Length to face of forks	l2 (mm)	375
Overall width	b1 (mm)	685
Fork dimensions	s/e/l (mm)	53/160/1150 (1220)
Width overall forks	b5 (mm)	520/550/685
Aisle width for pallets 1000x1200 (1200 crossways)	Ast (mm)	1725/1795
Aisle width for pallets 800x1200 (1200 lengthways)	Ast (mm)	1775/1795
Turning radius	Wa (mm)	1335/1405
Drive motor power	kW	0.9
Lift motor power	kW	0.8
Sound level at the driver's ear according to DIN12503	dB (A)	70
Travel speed, laden/unladen	Km/h	4/4.5
Battery voltage/nominal capacity K20	V/Ah	24/105
Battery dimensions l/w/h	mm	260/169/215
Battery weight	Kg	49
Service weight (with battery)	Kg	250

## P2.0UTE Power Plug Type





# HYSTER® DEALERS

Contact your nearest Hyster® Dealership  
by visiting [www.hyster.com.au](http://www.hyster.com.au)

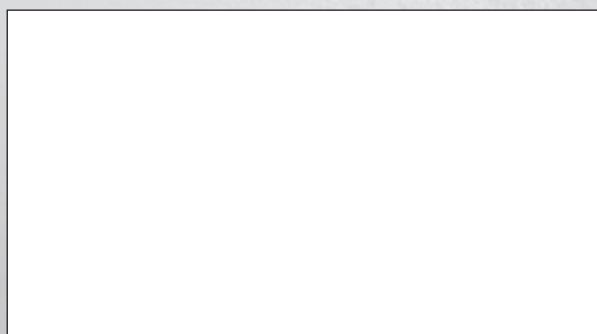

## HYSTER PACIFIC

1 Bullecourt Avenue, Milperra NSW, Australia 2214  
Tel: +61 (2) 9795 38007 Fax: +61 (2) 9792 8484  
[hyster.com/pacific/en-au](http://hyster.com/pacific/en-au)

## HYSTER ASIA

16 Tuas Avenue 20, Singapore 638827  
Tel: +65 6863 3387 Fax: +65 6863 3349  
[hyster.com/asia/en-sg](http://hyster.com/asia/en-sg)



/Hysterasiapacific



HysterJAPIC



Hyster Asia-Pacific