



**STRONG PARTNERS.
TOUGH TRUCKS.™**

J30-40XN/XNT SERIES

THREE- AND FOUR-WHEEL, COUNTERBALANCED ELECTRIC FORKLIFT

WWW.HYSTER.COM

> J30-40XNT/XN SERIES

The J30-40XNT/XN series of electric lift trucks from Hyster Company offers numerous advantages in performance and ergonomics that make them some of the most operator friendly AC-powered lift trucks on the market.

The innovative design of our three-wheel and four-wheel electric trucks provides you with a variety of solutions depending on your needs. The compact design and tight turning radius of the three-wheel truck gives you incredible maneuverability in the tightest locations. The four-wheel truck, with its Zero Turning Radius (ZTR) axle offers maneuverability similar to a three-wheel truck, with greater comfort when traveling over longer distances.

Superior operator comfort and customizable performance, that matches operator skill with individual performance needs, enable the J30-40XNT/XN to give maximum productivity throughout the entire shift.

The J30-40XNT/XN delivers more bottom-line savings by increasing productivity and uptime through the use of AC motors and transistor controller technology for all traction and hydraulic systems, which reduce the frequency and cost of maintenance.

Using cutting-edge components and intelligent system design, the J30-40XNT/XN operates longer, with minimal downtime, and is assembled on a state-of-the-art assembly line utilizing the latest in manufacturing processes and techniques.





> RAISING THE STANDARD

A EXCLUSIVE VISTA™ MAST

High strength hot-rolled steel mast channels and flush-faced design improve capacity retention at high lifts. Compact cast steel cross members optimize visibility and rigidity. Six canted 3-inch full-face load rollers roll on the web and the flange simultaneously, eliminating the need for side thrust rollers or wear plugs.

B TILT STEER COLUMN

The infinitely adjustable tilt steer column with optional telescopic column and tilt memory accommodates all operators easily. Assisted by a gas-spring and an easy-to-reach lever, obtaining your preferred position is simple.

C REMOVABLE FLOOR PLATE

Two-piece steel floor plate and side plates are easily removed to provide instant service access. A thick molded rubber floor mat seals the floor area to reduce noise and vibration for a more comfortable ride.

D PACESETTER VSM

The computer "brain" of these lift trucks manages all vehicle systems to optimize performance, significantly increases overall reliability and enhances diagnostic capability to give maximum uptime.

E DRIVE AXLE

The sealed design of the drive axle enhances dependability and reliability for a longer service life. Hyster oil-cooled wet disc brakes provide smooth stopping with reduced pedal effort as well as long brake life.

F SEALED TRANSMISSION

Transmission is lubricated for life so there is no need to change the transmission oil.

G AC MOTORS

The brushless AC traction and hydraulic motors, powered by transistor controls, are durable enough to handle your toughest duty cycle, with reduced maintenance costs and enhanced productivity.

H OVERHEAD GUARD

The unique grid-style pattern improves visibility while protecting operators and strengthening the truck's structure. The front, curved OHG leg design affords greater shoulder clearance for easier operator entry and exit.

I LED LIGHTS

Bright and long lasting, the optional LED front and rear working lights and brake / tail / back-up lights rarely need replacing. The plastic lens meets the FDA requirement for use in food applications.

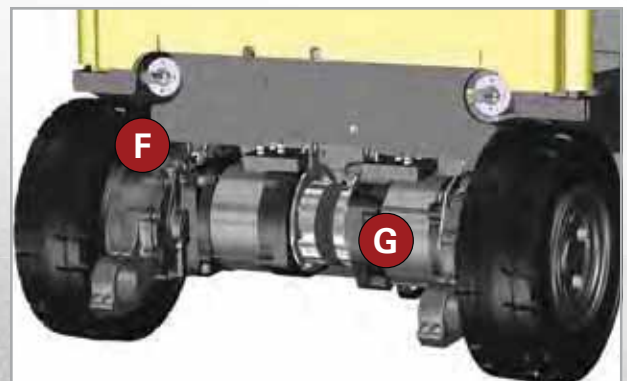



J MULTIFUNCTION DISPLAY

The location of the multifunction display provides maximum forward visibility and ease of operation. The display does not obstruct the forward view and is within easy reach of the operator, supervisor or service technician for quick access to truck functions, diagnostics and troubleshooting.

K FATIGUE-REDUCING OPERATOR COMPARTMENT

Ergonomically designed operator compartment helps enhance overall productivity. Features include: increased foot space and optimized step height for easy entry and exit; fully adjustable, full suspension seat (optional) with low whole body vibration levels; infinitely adjustable steering column with optional memory tilt and telescopic steering wheel and low effort e-hydraulic controls. The standard non-suspension seat and optional suspension and swivel seats are all easily adjusted to provide a more customized, comfortable ride.

L REAR DRIVE HANDLE

Optional handle provides an excellent hand hold for reverse driving while giving ready access to the auxiliary horn button for use when approaching cross-aisles and pedestrian traffic areas.

M FOUR-WHEEL DESIGN

The J30-40XNT/XN series features a Zero Turn Radius (ZTR) steer axle which provides advanced turning capability and superb maneuverability during operation. The Hyster Stability System reduces truck lean in turns, allowing superior travel over uneven surfaces. The stability system requires no maintenance.

N THREE-WHEEL DESIGN

The J30-40XNT/XN series three-wheel configuration provides a tighter turning radius for unparalleled maneuverability that makes stacking in limited space and congested loading bays easier than ever. The dual steer wheels provide a smoother, more stable ride. The rack-and-pinion hydraulic actuator is sealed from contaminants and moisture for reliable, maintenance-free operation.

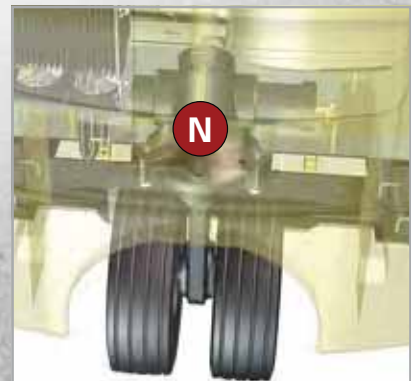
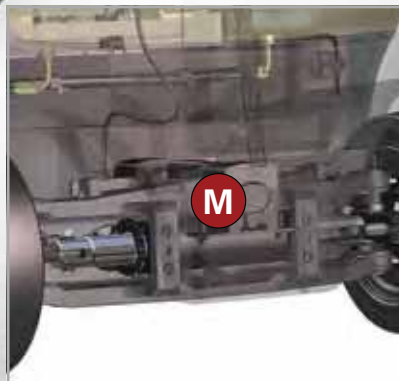

> SUPERIOR COMFORT COMES STANDARD

The superior ergonomic design of the J30-40XNT/XN means greater comfort for your operator. Enhanced ergonomics combined with customizable performance characteristics enhance overall productivity and uptime.

SUPERIOR OPERATOR COMPARTMENT

- Easy-to-use 3-point entry design of operator compartment uses a large molded hand grip, hip restraint and open anti-slip step with a low step height to minimize muscle/joint strain during entry/exit.
- Seat is rotated 3° to the right for a more natural operating position and the optional full suspension seat offers adjustable weight control, easy fore/aft adjustment, and an adjustable seat back angle for the most comfortable working position.
- Uncluttered floor area and thick rubber floor mat provide greater operator comfort. Forward placement and angle of pedals provide more operator foot room. Placement and size of brake pedal allows actuation with either foot.

HYDRAULIC CONTROLS

- Standard Seat Side Mechanical Levers are positioned for maximum operator comfort and offer an optional integrated thumb-actuated directional control switch.
- Optional Electro-Hydraulic Controls with TouchPoint mini-levers provide precise fingertip control of all hydraulic functions. An adjustable armrest, mounted on the operator seat, positions the mini-levers in the most comfortable and efficient position. The armrest is cushioned and contoured to provide full forearm support. The hydraulic functions, seat side directional control switch, horn and power disconnect button are all incorporated in the armrest to maximize operator comfort and ease of use.

MINIMAL EFFORT OPERATION

- Improved brake pedal layout and the minimal braking requirements of the Auto Deceleration System significantly reduce operator fatigue.
- An infinitely adjustable steer column, and optional telescopic steer column with tilt memory, assures the right fit for any operator.
- A choice of 6 different seats enables a more customizable level of operator comfort through its enhanced design and adjustable features.
- Increased shoulder clearance — a result of the redesigned front curved overhead guard leg.
- The standard 12-inch steering wheel with integrated spinner knob reduces fatigue, provides more knee room, and goes lock-to-lock in just 4 turns for superior efficiency, maneuverability and control.
- Automatic Park Brake automatically applies the park brake when the truck is stationary and releases the park brake when the accelerator pedal is depressed.
- Rear drive handle (optional) provides an excellent hand hold for reverse driving while giving ready access to the auxiliary horn button for use when approaching cross-aisles and pedestrian traffic areas.



Three-point entry into operator compartment



Safelite The "AND CULTURE and" CUSTOMER

BELRO US

HYSTER

HYSTER40

> MAKE THE MOST OF YOUR WORK DAY

Increase throughput and sales volume while reducing operating costs. Productivity means moving more of your loads in less time with less cost. The Hyster® J30-40XNT/XN series has been proven to be a leader in productivity.

SUPERIOR OPERATOR CONTROL

- Exclusive VISTA™ Mast provides fast lift and lower speeds combined with improved visibility to make the VISTA mast among the best in the industry.
- The optional integral sideshift provides excellent visibility and affords greater capacities than carriage mounted sideshifts.
- Low effort, ergonomically placed seat side hydraulic levers, with optional thumb-actuated seat side directional control provide operator comfort minimizing fatigue and maximizing productivity.
- Choose from the seat side directional control or the Hyster-exclusive MONOTROL® pedal for quicker, smoother control of travel speed and direction, improving operator efficiency and further enhancing productivity.
- Infinitely adjustable tilt steer column provides increased comfort and minimizes fatigue.
- On-demand hydrostatic steering provides low effort steering and superior control with reduced noise.
- Power-assisted braking improves brake life while reducing operator effort.



OPERATOR COMPARTMENT

- Multifunction Display, located in the upper right corner of the operator's compartment, offers greater visibility for the operator with a large, LCD back lit screen for easy viewing and indicator icons for at-a-glance system status.
 - Battery State of Charge Indicator
 - Low Battery Lift Interrupt Program
 - Hour Meter
 - Performance Mode Indicator
 - Fault Indicator
 - Four Operator Selectable, Programmable Performance Modes
- The Operator Convenience Station provides industry-leading dash storage area creating a productive work environment for the operator with dedicated storage areas for markers, cell phone, PDA or 2-way radios, gloves, clipboards, pick tickets, beverages, flashlight, box-cutter—a place for almost anything an operator needs.

PERFORMANCE MODES

- Adjustment of customizable performance parameters to match your application needs is accessible via the multifunction display and technician password protection.
- A significant increase in loaded travel speeds and acceleration rates beyond the standard setting is possible when the Extended Shift setting is turned off.
- Our standard Extended Shift AC controller setting provides the optimum balance between performance needs and battery shift life.

AC TECHNOLOGY

- Delivers quick and smooth changes in travel direction, offers precise speed control with excellent acceleration, significantly increasing productivity.
- The standard Extended Shift feature allows enhanced run time without recharging over longer periods.
- Maintains top speed regardless of load or battery discharge level when Extended Shift is off.
- AC transistor hydraulic control enables precise load handling with greater efficiency and less noise.
- Hyster-designed thermal management system maximizes performance during continuous operation, while preventing damage to components due to heat.



High Visibility Multifunction Display



Versatile Operator Convenience Station

> **LITTLE TO OWN. LOTS TO APPRECIATE.**

The Hyster® J30-40XNT/XN series lowers your cost of operations by delivering enhanced productivity, lower energy consumption, advanced dependability, and reduced maintenance costs. The standard AC traction and hydraulic motors set the standard in materials handling, significantly reducing maintenance requirements.

BRUSHLESS AC TECHNOLOGY

- Eliminates motor brushes.
- Requires no periodic maintenance.
- Eliminates scheduled downtime and the cost for parts and service.
- Eliminates the service requirements created by brush wear dust.
- Does away with the commutator and its related parts and service costs.

SUPERIOR SERVICEABILITY

- The J30-40XNT/XN series utilizes CANbus communications to simplify wiring and improve serviceability.
- State-of-the-art on-board diagnostics reduce repair time and minimize expensive part-swapping.
- Direct access for service is a key element for easier daily checks or service, resulting in improved productivity.
- Easy battery access is provided via the gas spring-assisted hood and quick release handle.

VEHICLE SYSTEM MANAGER

All vehicle systems are managed electronically to optimize performance and significantly increase overall reliability, enhancing diagnostic capabilities to maximize uptime. The Pacesetter VSM (Vehicle System Manager) enables customization of truck performance to suit application needs.

- Communicates with motor controllers and operator display via CANbus.
- Monitors truck functions and stores data.
- Advanced thermal management and truck diagnostics.
- Interfaces Service and Diagnostic Tools.
- Interfaces all operator control devices.
- Interfaces all on-board sensors.

UNRESTRICTED SERVICE ACCESS

- Two-piece floor plate and step plate can be easily removed for access to the brake fluid reservoir, hydraulic valve, VSM, tilt cylinders
- Lift-out floor plate requires no tools for quick and easy daily operator checks.

LOWEST ENERGY CONSUMPTION

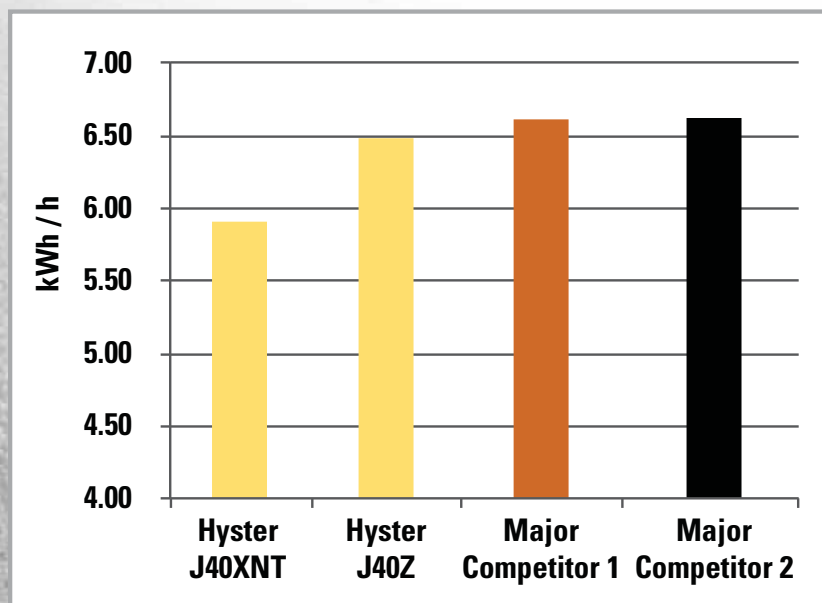

According to the VDI Energy Cycle Standardized Test, the Hyster J30-40XNT/XN series provides the lowest energy consumption versus the competition. Better energy utilization saves money and reduces impact on the environment.



WORLD-CLASS DEPENDABILITY

- Oil-Cooled Wet Disc Brakes are completely sealed from water and other contaminants for extremely long brake service life.
- Auto Deceleration System extends brake life by automatically slowing the truck through regenerative braking when the accelerator pedal is released.
- Easy-to-use on-board diagnostics through the multifunction display provide fast and accurate troubleshooting for first-time fixes.
- Optional electronic monitoring package reports low fluid level and hydraulic oil filter restrictions.
- Optional LED work lights, brake lights, and tail lights resist vibration and rarely need service.
- Unitized frame construction provides excellent durability and stability, boosting driver confidence and enhancing productivity.

THERMAL MANAGEMENT SYSTEM

- Large Air Inlet Ports in the rear of the truck are protected, and strategically positioned to provide fresh air intake for controller cooling.
- A heat sink is used to draw heat away from the motor controllers. Additional cooling for continual high ambient operation is provided by cooling fans above the heat sink.
- The Hyster-designed thermal management system continuously monitors the J30-40XNT/XN series critical truck functions. Upon identifying an irregularity, it protects the components by automatically adjusting truck performance.

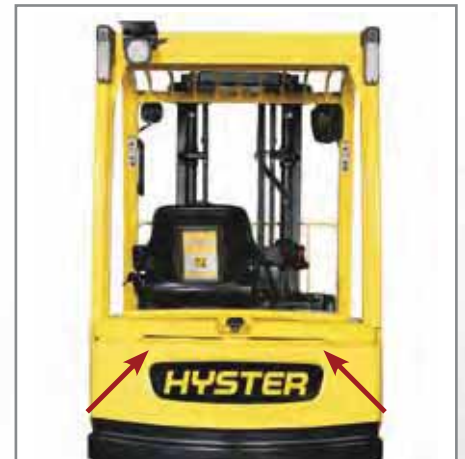

Large Air Inlet Ports

INDUSTRIAL STRENGTH ELECTRONICS

- CANbus communications network reduces wiring complexity, providing superior dependability.
- Non-mechanical, Hall-Effect sensors and switches are designed to outlast the life of the truck.
- Proven tough, Pacesetter VSM industrial on-board computer manages truck operation to maintain world-class dependability and maximize uptime.
- Double-sealed electrical connectors provide waterproof and contaminant protection.
- Smart, one-way routing path for wire harnesses ensures consistent high-quality assembly while increasing durability and simplifying maintenance when needed.

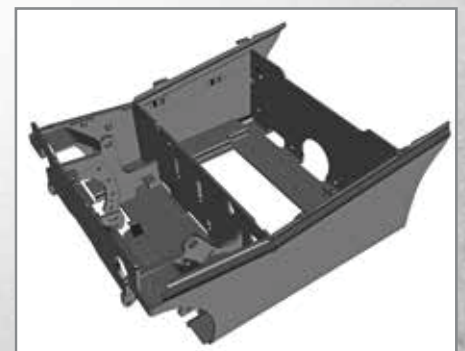

Rugged Unitized Frame

HASSLE-FREE HYDRAULICS

- Leak-free O-ring face seal fittings reduce leaks for enhanced reliability.
- A 10-micron high-performance in-tank filtration system captures 99.5% of hydraulic system debris, significantly extending component life.
- Smart placement of the control valve and hydraulic lines away from heat sources reduces operating temperature, extending the life of seals and hoses for exceptional reliability.

INNOVATIVE TRUCKS ENGINEERED TO MEET THE MOST DEMANDING APPLICATIONS

For nearly 90 years, Hyster has conquered the world's most demanding applications. In the 1920s Hyster started as a manufacturer of lifting machines used in the rigorous logging industry of the United States' Pacific Northwest. A few years later the first forklift trucks were invented and the Hyster brand quickly gained its reputation for rugged quality. Hyster® lift trucks are designed to lower your cost of operations. Every truck we make — whether powered by gasoline, LPG, diesel, electric, CNG, lithium-ion or hydrogen fuel cells — is purpose-built to excel in its application. Every truck is also backed by an unmatched network of specialists.



Dealer Network — Our Dealer Network can offer the expertise of fleet managers, parts suppliers, capital procurement specialists and trainers. Carefully chosen dealers fully understand customer applications, assist in selecting the right lift truck and provide fast, reliable support.



Hyster Fleet Services — Even if you operate other brands, we can manage your maintenance and replacement plan. We can offer complete fleet analysis, fleet history summary and a cost-effective proposal for replacement and scheduled maintenance.



Parts — With genuine Hyster® replacement parts and UNISOURCE™ parts for all makes of lift trucks, we are your one-stop source for lift truck parts. In fact, we offer more than 7 million part number crosses for most brands of materials handling and other in-plant mobile equipment.



Rental Products — When leasing or buying isn't a practical option, we have access to more than 14,000 units for short- and long-term rental. We'll help you maintain output in a cost-effective manner.



Hyster Capital — We can arrange solutions for special financing requirements, taking the difficulties out of buying the equipment you need. Whether you purchase or lease a new or used lift truck, Hyster Capital offers superior service and competitive rates.



Special Products Engineering Department (SPED) — Different materials require different handling. That's why we can work with you to customize your lift trucks. From strobe lights to specially made forks, SPED has the tools to help you get the job done right.



Operator Training — Proper education in operating lift trucks minimizes the risk of injuries due to accidents while increasing productivity. Hyster offers OSHA-compliant materials that support the training of qualified operators.



Service — Your local Hyster® dealer offers a flexible, customized and comprehensive maintenance plan based on each lift truck's operation environment. Hyster service programs offer scheduled inspections and maintenance, along with quick, responsive service dispatched to your location.



Hyster Company
P.O. Box 7006
Greenville, North Carolina
27835-7006
Part No. J30-40XNT/XN/B
3/2018 Litho in U.S.A.

Visit us online at www.hyster.com or call us at **1-800-HYSTER-1**.

Hyster,  and STRONG PARTNERS. TOUGH TRUCKS. are registered trademarks in the United States and certain other jurisdictions. Hyster products are subject to change without notice.

Trucks may be shown with optional equipment. © 2018 Hyster Company. All rights reserved.