



**STRONG PARTNERS.
TOUGH TRUCKS.™**



PLATFORM PALLET TRUCK

AP2.0MS

2 000 KG



AP2.OMS - MECHANICAL SPECIFICATIONS

CHARACTERISTICS	MANUFACTURER			HYSTER								
	Model designation			AP2.OMS								
	Wheelbase type			Single Load Wheels			Tandem Load Wheels					
	Fork length	mm		1125	1173	1171						
Outside fork width	mm		520	560	570	520	560	670	520	560	670	
DIMENSIONS	1.3	Power: battery, diesel, LPG, electric mains		Battery			Battery			Battery		
	1.4	Operation: manual, pedestrian, stand, seat, orderpicker		Pedestrian/Stand			Pedestrian/Stand			Pedestrian/Stand		
	1.5	Load capacity	Q (kg)	2000			2000			2000		
	1.6	Load centre	c (mm)	600			600			600		
	1.7	Load distance, centre of drive axle to fork	x (mm)	893			942			896		
	1.8	Wheelbase	y (mm)	1303			1352			1304		
WEIGHTS	2.1	Unladen weight (with battery)	kg	728			730			730		
WHEELS & TYRES	3.1	Tyres: rubber, polyurethane, Vulkollan front/rear		Poly/Poly			Poly/Poly			Poly/Poly		
	3.2	Tyre size, front		Ø 230x75			Ø 230x75			Ø 230x75		
	3.3	Tyre size, rear		Ø 85x110			Ø 85x110			Ø 85x110		
	3.4	Additional wheels (dimensions)		Ø 125x50			Ø 125x50			Ø 125x50		
	3.5	Wheels, number front/rear (x = driven)		1X + 2/2			1X + 2/2			1X + 2/4		
	3.6	Track width, front	b ₁₀ (mm)	473			473			473		
	3.7	Track width, rear	b ₁₁ (mm)	350	390	500	350	390	500	350	390	500
DIMENSIONS	4.15	Lowered height	h ₁₃ (mm)	83			83			83		
	4.19	Overall length (Pedestrian/Stand)	l ₁ (mm)	1796/2241			1844/2289			1842/2287		
	4.2	Length to face of forks (Pedestrian/Stand)	l ₂ (mm)	671/1116			671/1116			671/1116		
	4.21	Overall width	b ₁ /b ₂ (mm)	712			712			712		
	4.22	Fork dimensions	s/e/l (mm)	64	170	1125	64	170	1173	64	170	1171
	4.25	Outside fork width	b ^s (mm)	520	560	670	520	560	670	520	560	670
	4.32	Ground clearance centre of wheelbase	m ₂ (mm)	21			21			21		
	4.33	Aisle width with pallets 1000mm x 1200mm wide (Pedestrian/Stand)	Ast (mm)	1879/2317			N/A			N/A		
	4.34	Aisle width with pallets 800mm x 1200mm long (Pedestrian/Stand)	Ast (mm)	N/A			2077/2515			2079/2517		
	4.35	Turning radius (Pedestrian/Stand)	W ₃ (mm)	1572/2010			1619/2057			1572/2010		
	4.4	Lift height	h ₃ (mm)	130			130			130		
4.9	Height of tiller arm in drive position min/max	h ₁₄ (mm)	1219	1459		1219	1459		1219	1459		
PERFORMANCE	5.1	Travel speed with/without load (Pedestrian/Stand)	km/h	6/6	8/8		6/6	8/8		6/6	8/8	
	5.2	Lift speed with/without load	m/s	0.04	0.05		0.04	0.05		0.04	0.05	
	5.3	Lowering speed with/without load	m/s	0.09	0.04		0.09	0.04		0.09	0.04	
	5.8	Max gradeability with/without load	%	14.5	20		14.5	20		14.5	20	
	5.10	Service brake		Electric			Electric			Electric		
MOTOR	6.1	Drive motor, S2 60 minute rating	kW	1.4			1.4			1.4		
	6.2	Lifting motor, S3 15% rating	kW	1.2			1.2			1.2		
	6.3	Battery DIN 43531/35/36 A, B, C, no		B			B			B		
	6.4	Battery voltage/capacity at 5 hour rate	V/Ah	24/230	24/330		24/230	24/330		24/230	24/330	
	6.5	Battery weight +/-5%	kg	212/288			212/288			212/288		
	6.6	Energy consumption according to VDI cycle	kWh/h	0.43			0.43			0.43		
OTHER	8.1	Drive control		AC			AC			AC		
	8.4	Sound level at the driver's ear according to DIN 12 053	dB(A)	<70			<70			<70		



AP2.OMS - STANDARD FEATURES & OPTIONS

STANDARD FEATURES

- Battery Compartment 218mm
- Battery Size LxWxH (212x624x627)
- 24 Volt
- AC Traction Control
- Single Load Wheels
- 1125mm Long Forks (Australia only)
- 1173mm Long Forks
- 670mm Fork Spread
- Lift Motor Time-Out at Full Height
- Operating Temperatures: 0 to 49°C
- Flush Pallet Stop
- Electromagnetic Park Brake with Service Override
- Regenerative Braking
- Mold-On Polyurethane Drive Tyre (Ø 230x75)
- Adjustable Casters (Ø 125x40)
- Impact-Resistant, Ergonomically Designed, Mid-Mount Control Handle with Cushioned Return Spring
- Direction Reversing Switch
- Creep Speed "Turtle" Button
- Three User Selectable Performance Modes
- Hour Meter and Battery Discharge Indicator with Lift Interrupt

OPTIONAL FEATURES

- Tandem Load Wheels with 1171mm Fork Lengths
- Fork Spread
- 520mm Fork Spread
- 560mm Fork Spread
- Vulkollan Load Wheel
- Load Backrest
- 1219mm H
- 1524mm H
- Battery Compartment 290mm

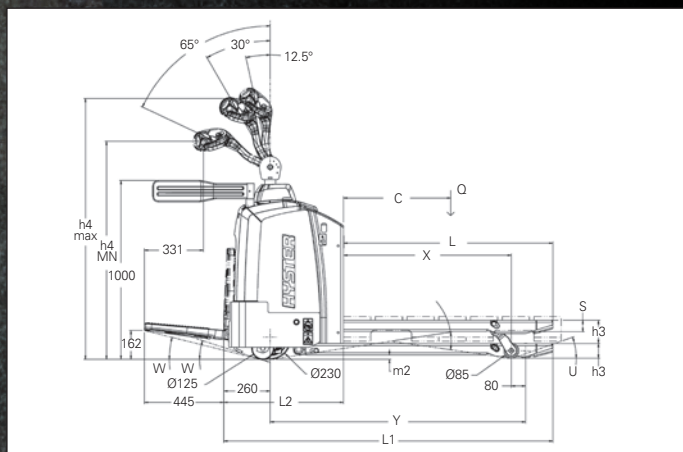
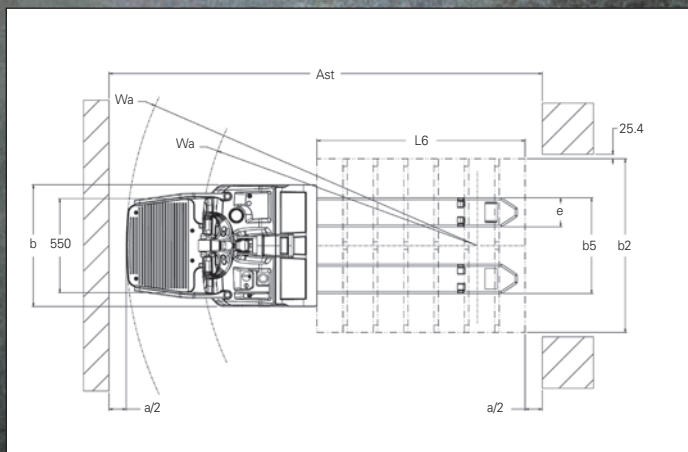



HYSTER® DEALERS

Contact your nearest Hyster Dealership
by visiting www.hyster.com



Contact your local Hyster Dealer



Safety. This truck conforms to the current EU requirements. Specification is subject to change without notice.



HYSTER ASIA PACIFIC

1 Bullecourt Avenue, Milperra NSW, Australia 2214

Tel: +61 (2) 9795 3800 Fax: +61 (2) 9792 8484



/Hysterasiapacific



@Hyster_AP

is a Registered Trademark.

HYSTER is a Registered Trademark. STRONG PARTNERS. TOUGH TRUCKS. is a trademark in the United States and certain other jurisdictions.
© Hyster Asia Pacific 2013. All rights reserved. Printed in Australia. Specifications and details in this brochure are subject to change without prior notification. Please consult with your Hyster dealer for the most up to date information and to confirm exact capacities. BR0000020/V1.0

HYSTER.COM